

ITEM NO.	DESCRIPTION
1	Hevel met dubbele cilinder
2	Veiligheidssticker
3	Fundatiekorrels tegen knaagdieren
4	Mantelbuis
5	Fundatie
6	Hoofdschakelaar
7	HAR
8	C-rail 500mm

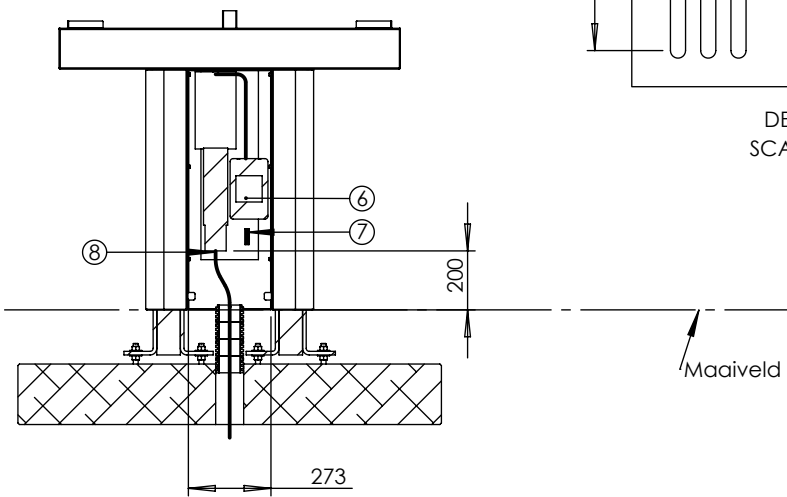

SECTION I-I
SCALE 1 : 25

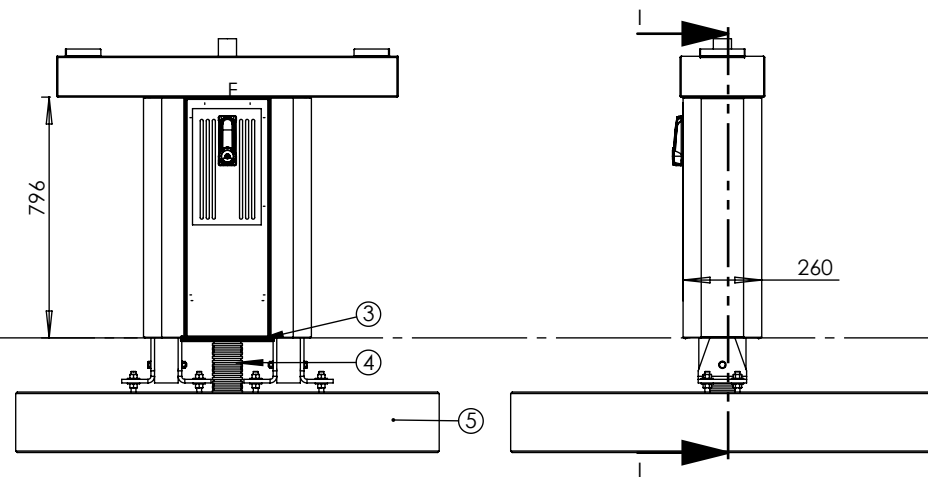
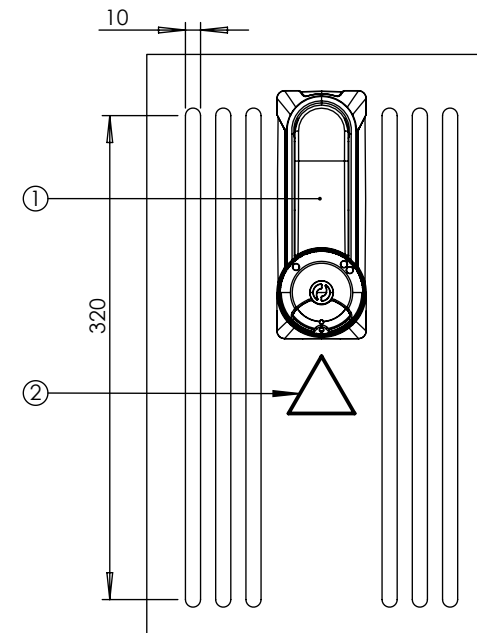

DETAIL F
SCALE 1 : 5

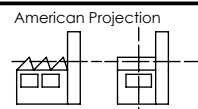

Scale : 1:25 A4
Units : mm
Date : 26-7-2024

Drawn : Ruben Kastelein
Project: MEX
Filename: PM-03-Support Netbeheerder

Material :
Mass : grams
Thickness :
Finish :

Remarks :

Kastelines
Industrial Design
Tel +31 610440516
ruben@kastelines.nl

Drawing Name :
SP-DIG23-Support Digital

Part-Assem number :
SPDIG23-02-000-00-00-000.02

Sheet number :
1 of 2

ITEM NO.	DESCRIPTION
1	Hevel met dubbele cilinder
2	Veiligheidssticker
3	Fundatiekorrels tegen knaagdieren
4	Mantelbuis
5	Fundatie
6	Hoofdschakelaar
7	HAR
8	C-rail 400mm

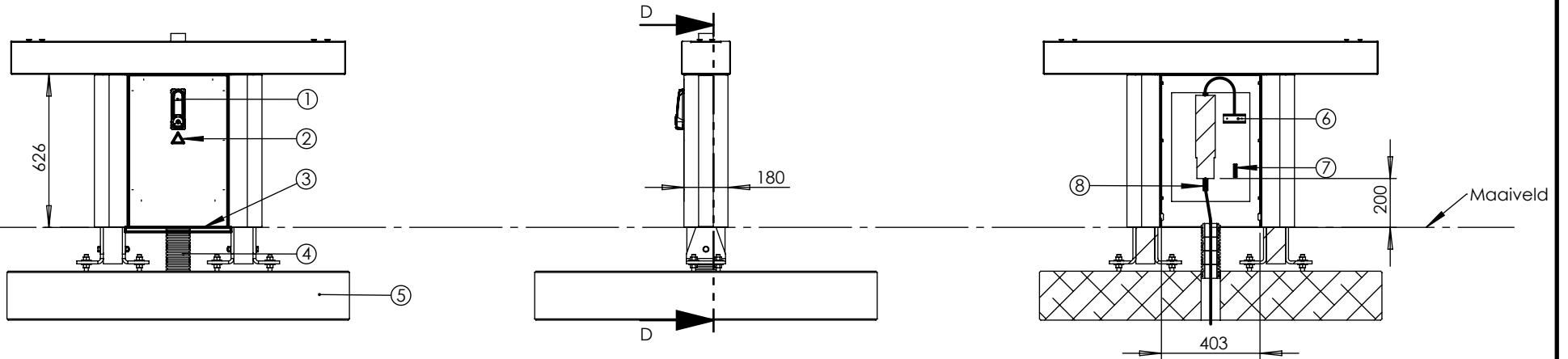

SECTION D-D

American Projection

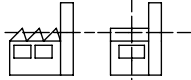

Scale : 1:10 A4

Units : mm

Date : 26-7-2024

Drawn : Ruben Kastelein

Project: MEX

Filename: PM-03-Support Netbeheerder

Material :
 Mass : grams
 Thickness :
 Finish :

Remarks :

Kastelines
 Industrial Design

Tel +31 610440516
 ruben@kastelines.nl

Drawing Name :
SP-DIG23-Support EP Static

Part-Assem number :
SPDIG23-03-000-00-00-000.00

Sheet number :
2 of 2