

General tolerances unless otherwise specified									
Tolerances for (robot)welding					Tolerances for lascutting			General tolerance for unspecified dimension	
Linear	<120	121-400	401-1000	1001-2000	2001<	Sheet thickness	Diameter	Linear < 500	Linear > 500
Tolerance	± 1 mm	± 1 mm	± 1 mm	± 1.5 mm	± 2 mm	1 t/m 6	± 0.1 mm	± 0.2 mm	± 0.3 mm
Flatness	0.4	0.75	1.5	2	3	10 t/m 12	± 0.15 mm	± 0.25 mm	± 0.35 mm
						15 t/m 25	± 0.25 mm	± 0.3 mm	± 0.4 mm
Quality level welded joints: DIN EN ISO 5817-C							General tolerance for unspecified dimension		
						Linear	± 0.5 mm	Angle	± 0.5 °

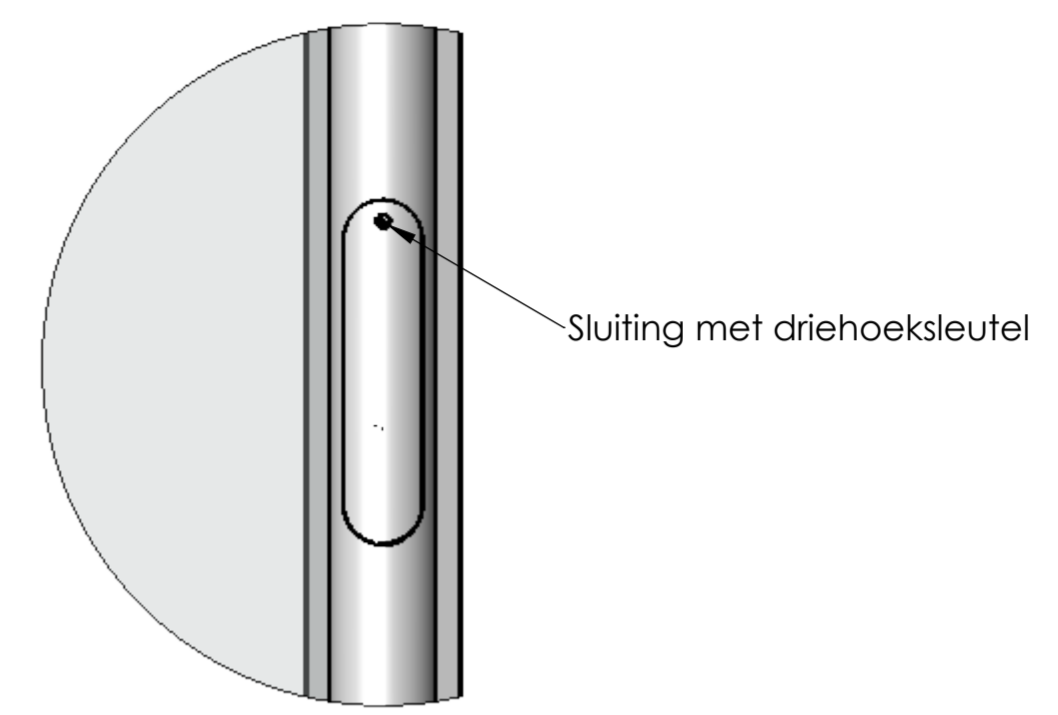

DETAIL E  
SCALE 1 : 10

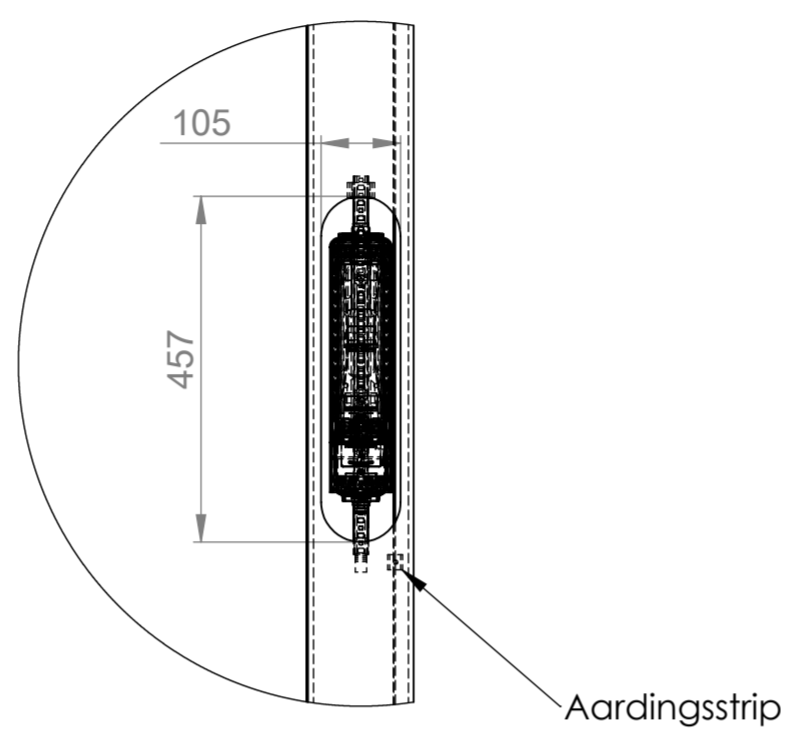
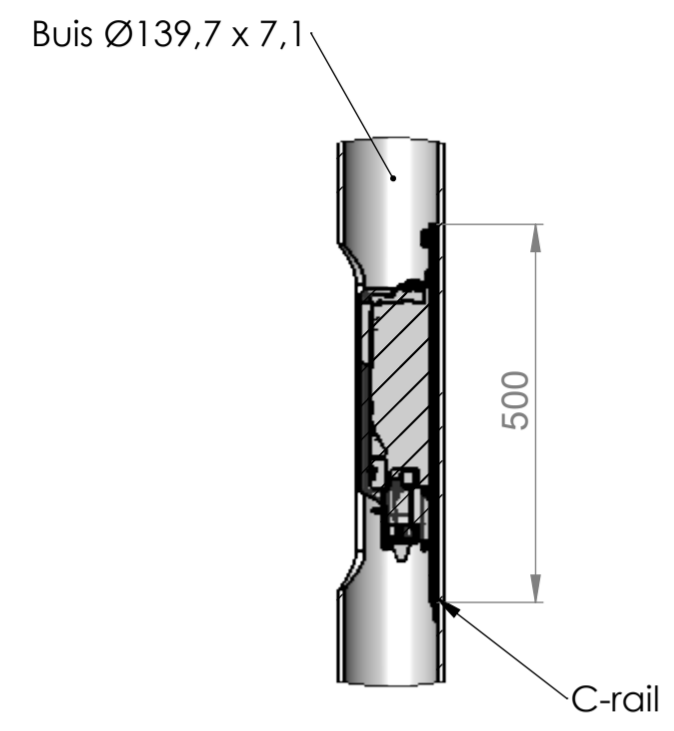
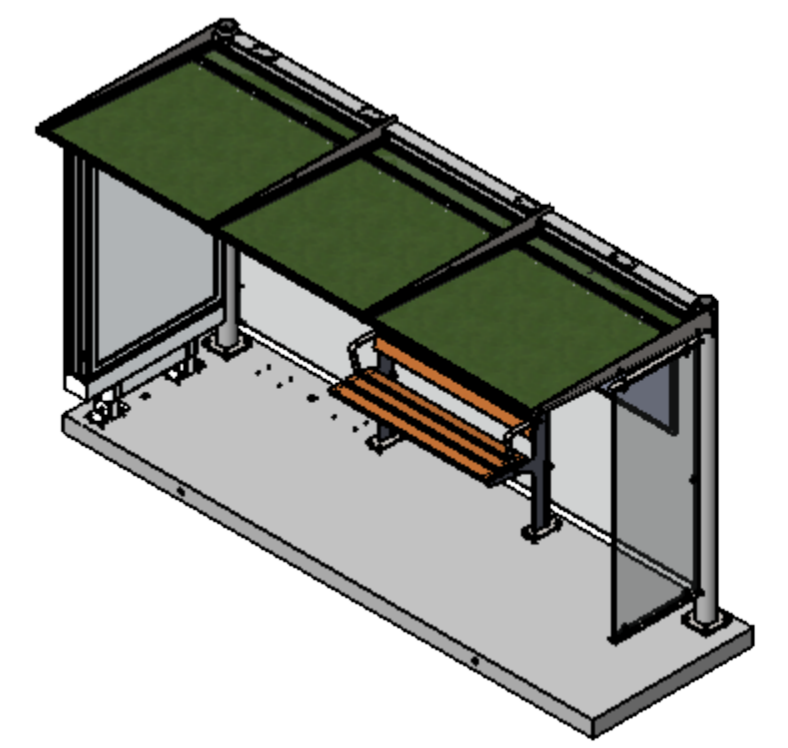
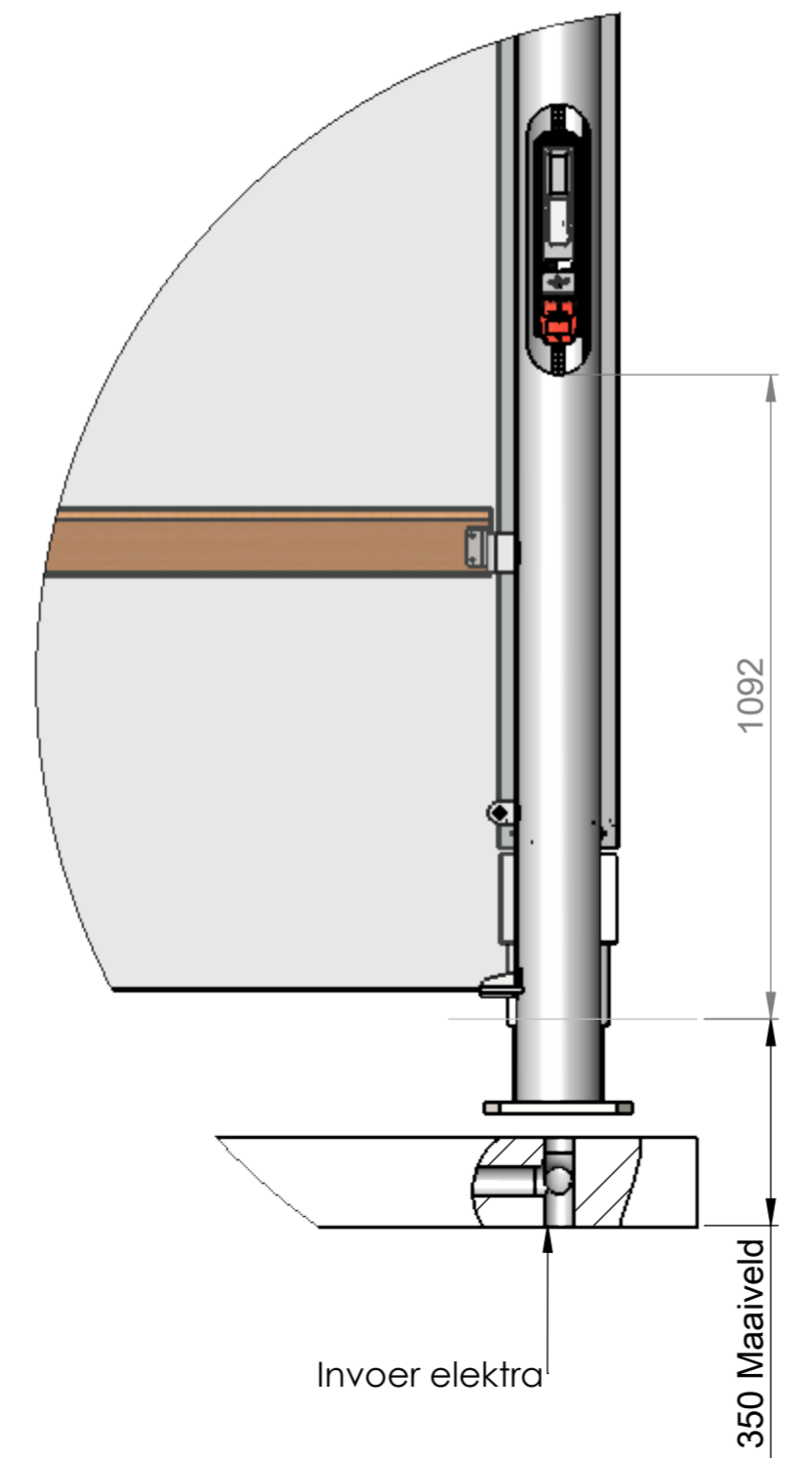
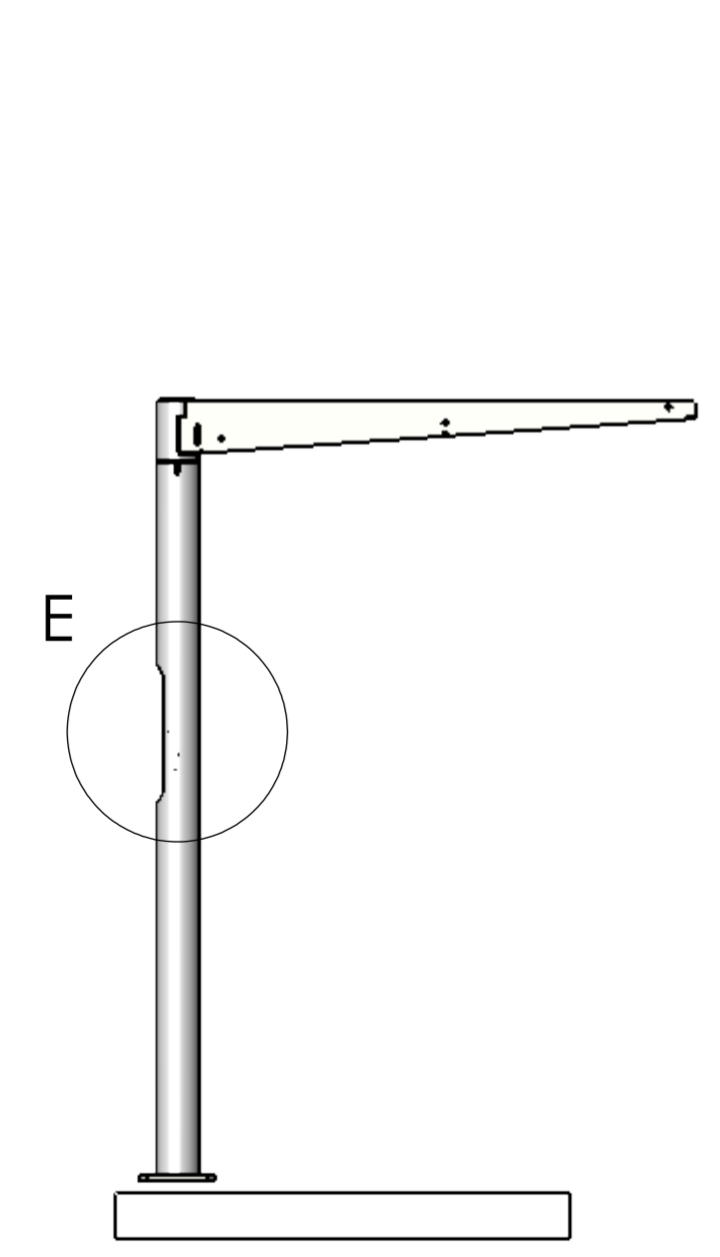

Opmerking		Description <b>Luxabri</b>		Revision -
Surface treatment / Finishing		Drawn by <b>JvdH</b>		Date
Material		Released by		Release date
Third angle	Roughness	Unit	mm	
	✓			
<b>VDL</b>		<b>VD Leegte Metaal</b>		Telephone 0497-331100 Email info@vdeegtemetaal.nl
Weight 3374964.39	Sheet 1	Number of sheets 1	Scale 1:25	Format A2

Alle rechten voorbehouden, geheel of gedeeltelijke  
 schriftelijke toestemming van de auteursrechtelijke  
 houder.  
 All rights reserved, reproduction in whole or in part is  
 prohibited without written consent of the copyright owner.