

Revisie overzicht		Naam	Controle
Rev.	Datum	Omschrijving	
04	29-6-2023	Diverse aanpassingen.	Tom Marco
05	10-7-2023	Diverse aanpassingen.	Tom R. van Laere

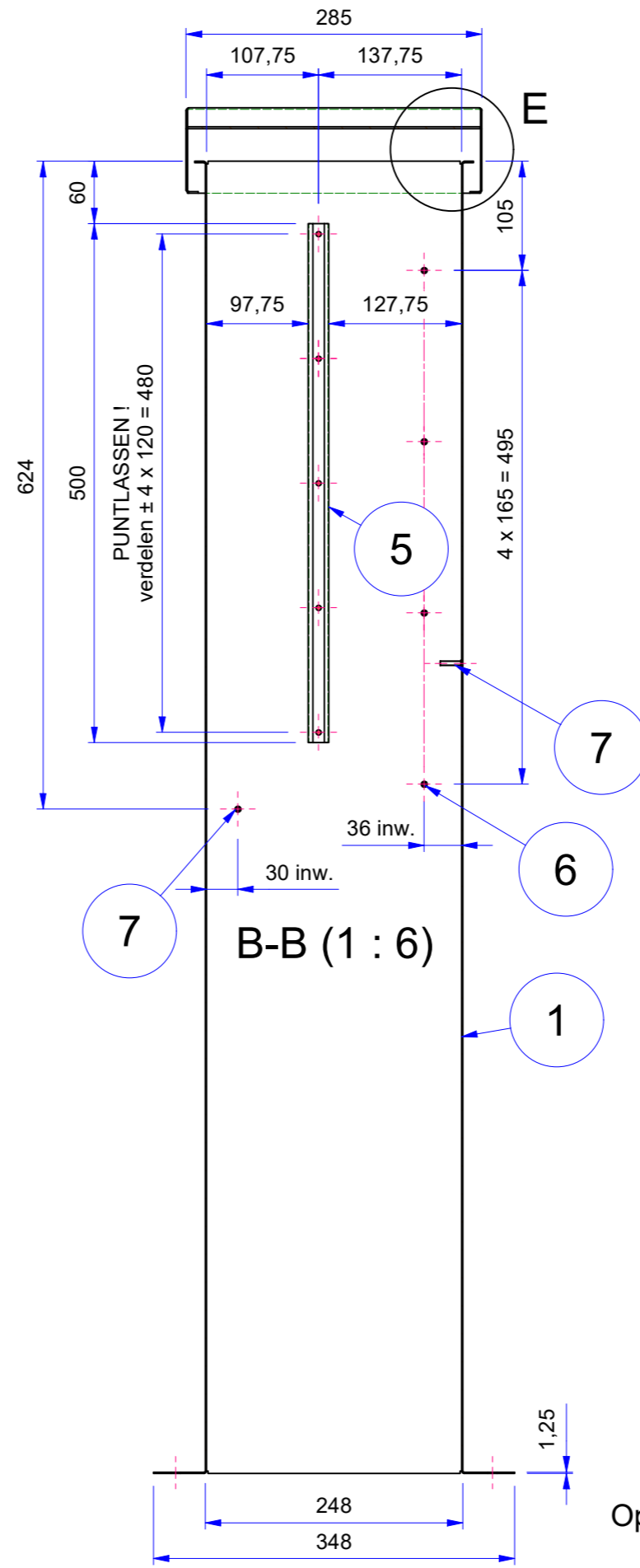

E (1:3)
Ventilatie

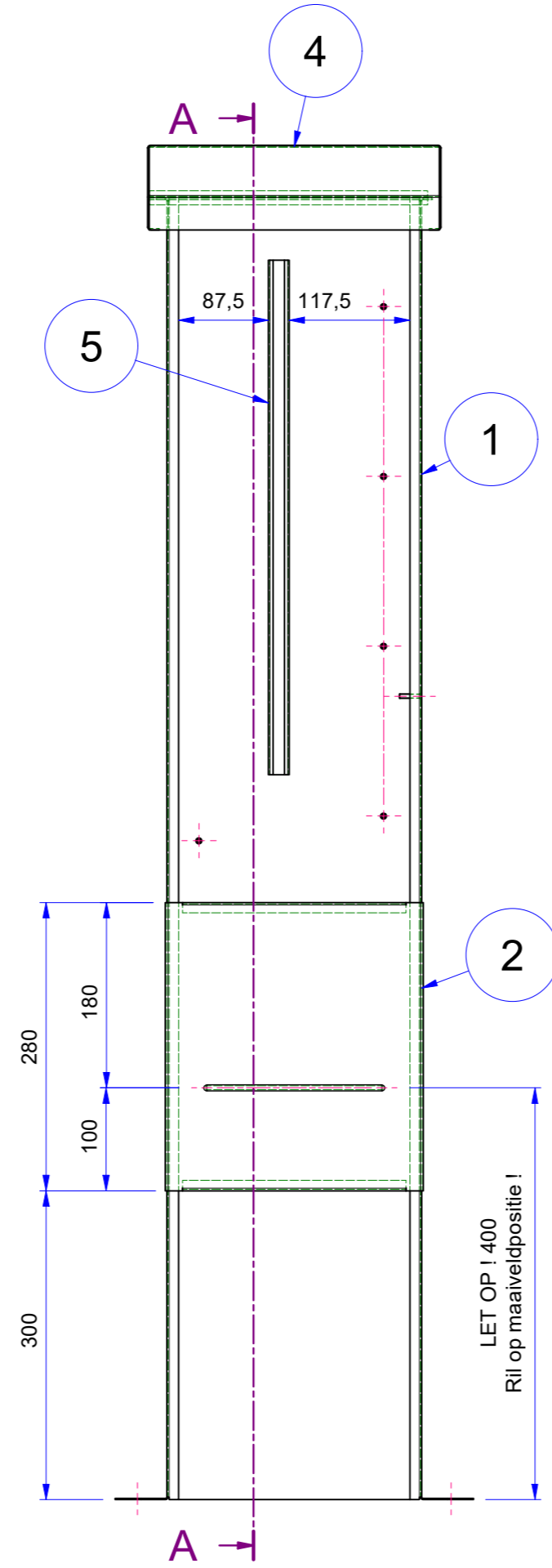
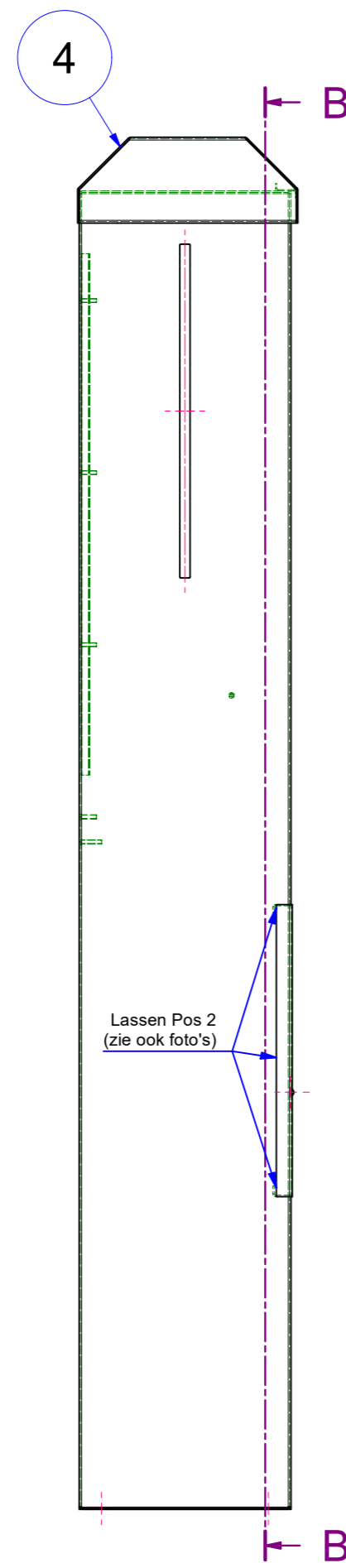
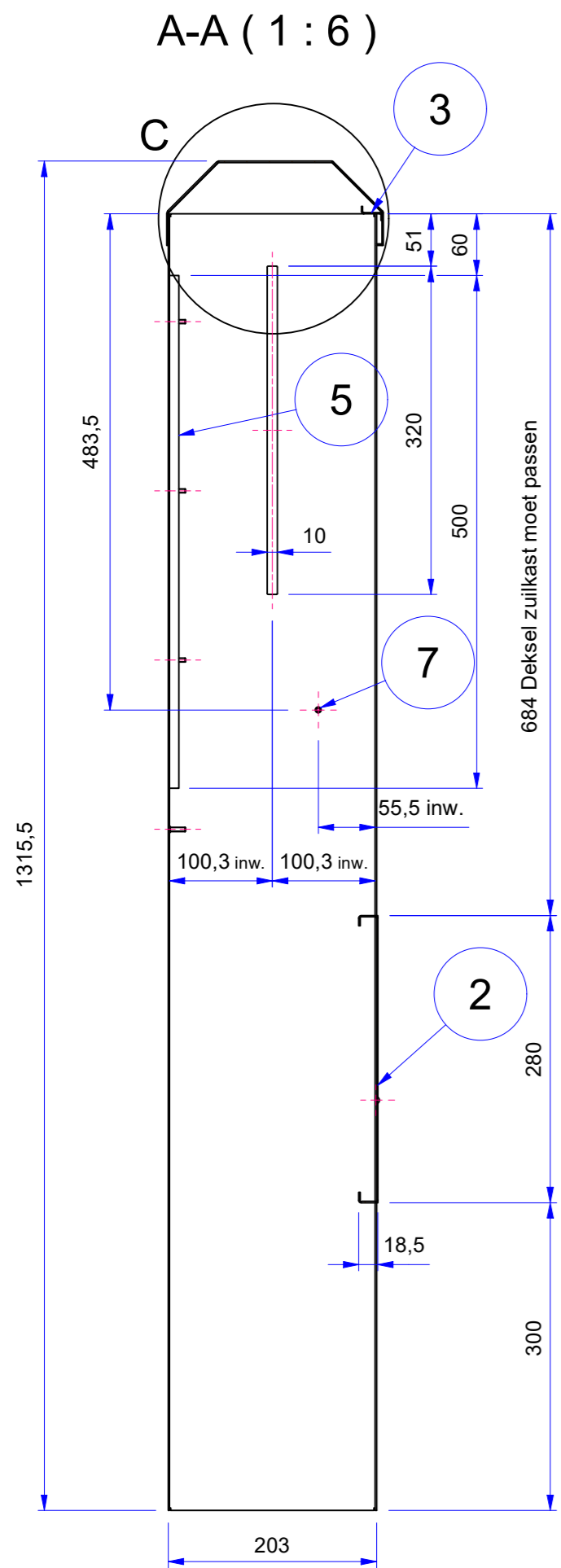
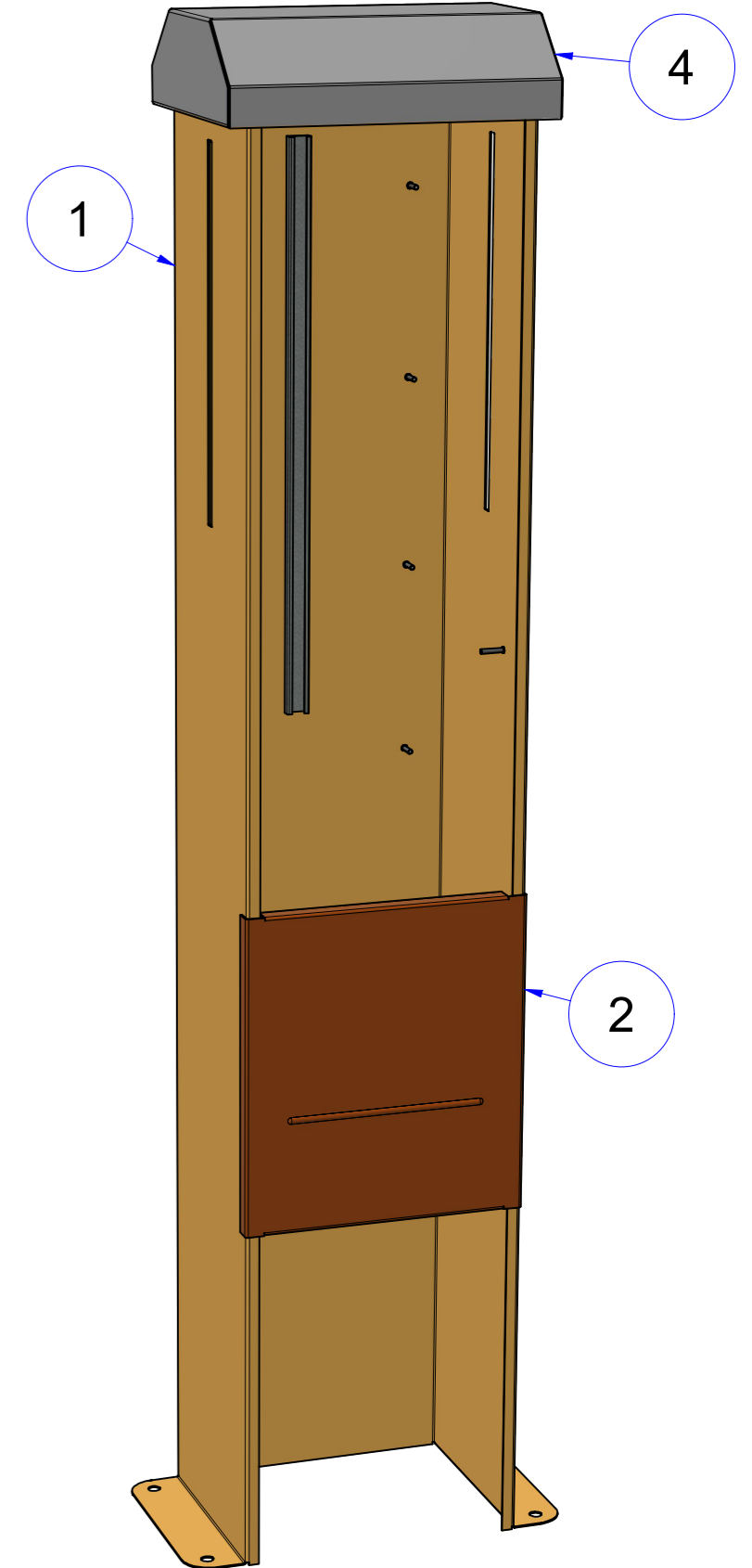
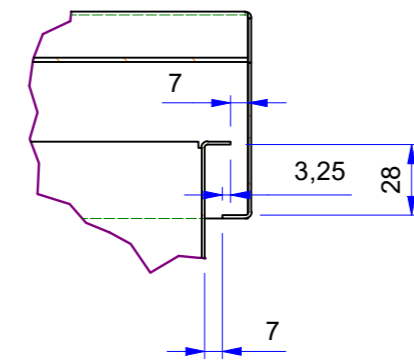

Opmerking :

- Deurtje 65026-002-00 moet goed passen, testen met slot.
- Tijdens nabehandeling schroefdraad afdoppen.
- 1x uitvoeren per Zuilkast breedte 248.

Pos	Aant	Artikelnummer	Omschrijving	Lengte	Breedte	Materiaal
7	2	6265-040020	Stiftlasbout CA2-DS-M0420	20,00 mm		RVS 304
6	4	6265-040015	Stiftlasbout CA2-DS-M0415	15,00 mm		RVS 304
5	1	65026-001-05	C-Profiel 0,75 mm	500,00 mm	41,80 mm	Sendzimir
4	1	65026-001-04	Deksel Zuilkast 1,25 mm	463,20 mm	314,49 mm	Zincor
3	1	65026-001-03	Aanslag Zuilkast 1,25 mm	270,00 mm	30,85 mm	Sendzimir
2	1	65026-001-02	Tussenstuk Zuilkast 1,25 mm	328,20 mm	276,10 mm	Sendzimir
1	1	65026-001-01	Zuil Zuilkast 1,25 mm	1322,35 mm	668,20 mm	Sendzimir

		Algemene toleranties : Maattolerantie : ± 0,5mm Hoektolerantie : ± 0,5°		Tenzij anders aangegeven op tekening	
Materiaal:		Afm:		Gewicht: 10,7 kg	
Klant: Reclamebureau Limburg bv		Amerikaanse projectie:		Tekeningsnummer / Artikelnummer:	
Getekend: Tom		Maak datum: 4-4-2023		Omschrijving:	
Gecontr.:		Controle datum:		Zuilkast behuizing	
Schaal: 1 : 6		Maateenheid: mm		Revisie:	
Status: Released		Blad: 1 / 1		Nabehandeling: Poedercoating RAL	
Cox Metaal B.V. Smakterweg 27, 5804 AE Venray (NL), tel: +31 478 510562, fax: +31 478 510946, www.coxmetaal.nl, info@coxmetaal.nl		Formaat:		A2	

C (1:3)

