

General tolerances unless otherwise specified									
Tolerances for (robot)welding					Tolerances for lasercutting				
Linear	<120	121-400	401-1000	1001-2000	2001->	Sheet thickness	Diameter	Linear < 500	Linear > 500
Tolerance	± 1 mm	± 1 mm	± 1 mm	± 1.5 mm	± 2 mm	1 t/m 6	± 0.1 mm	± 0.2 mm	± 0.3 mm
Flatness	0.4	0.75	1.5	2	3	10 t/m 12	± 0.15 mm	± 0.25 mm	± 0.35 mm
General tolerance for unspecified dimension									
Linear	± 0.5 mm				Angle	± 0.5 °			

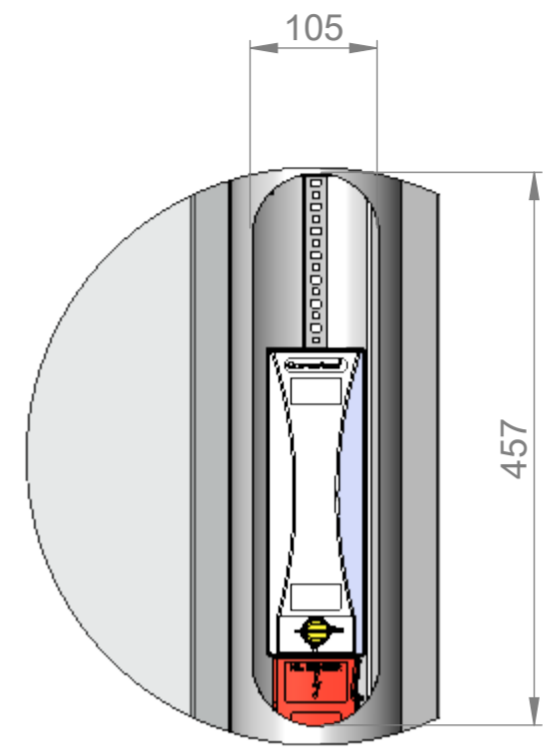

DETAIL D
SCALE 4 : 25

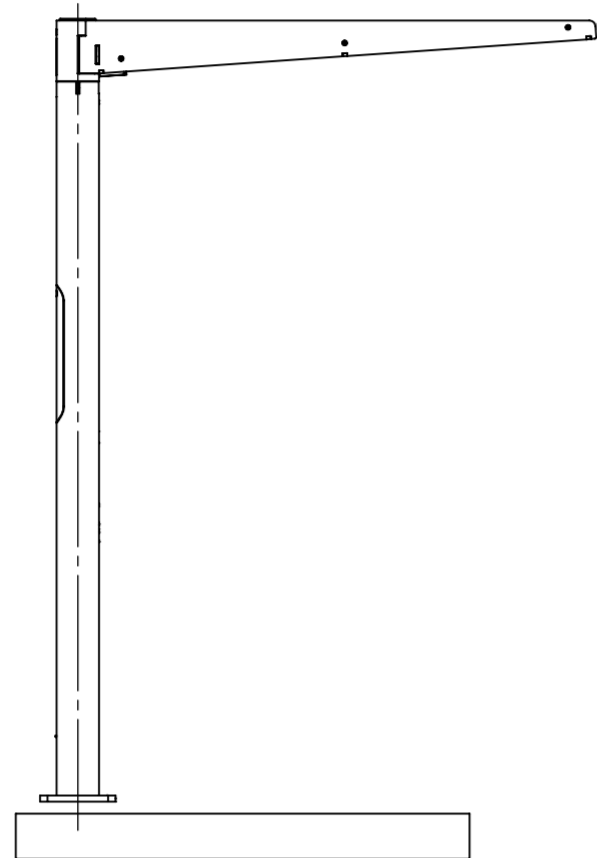
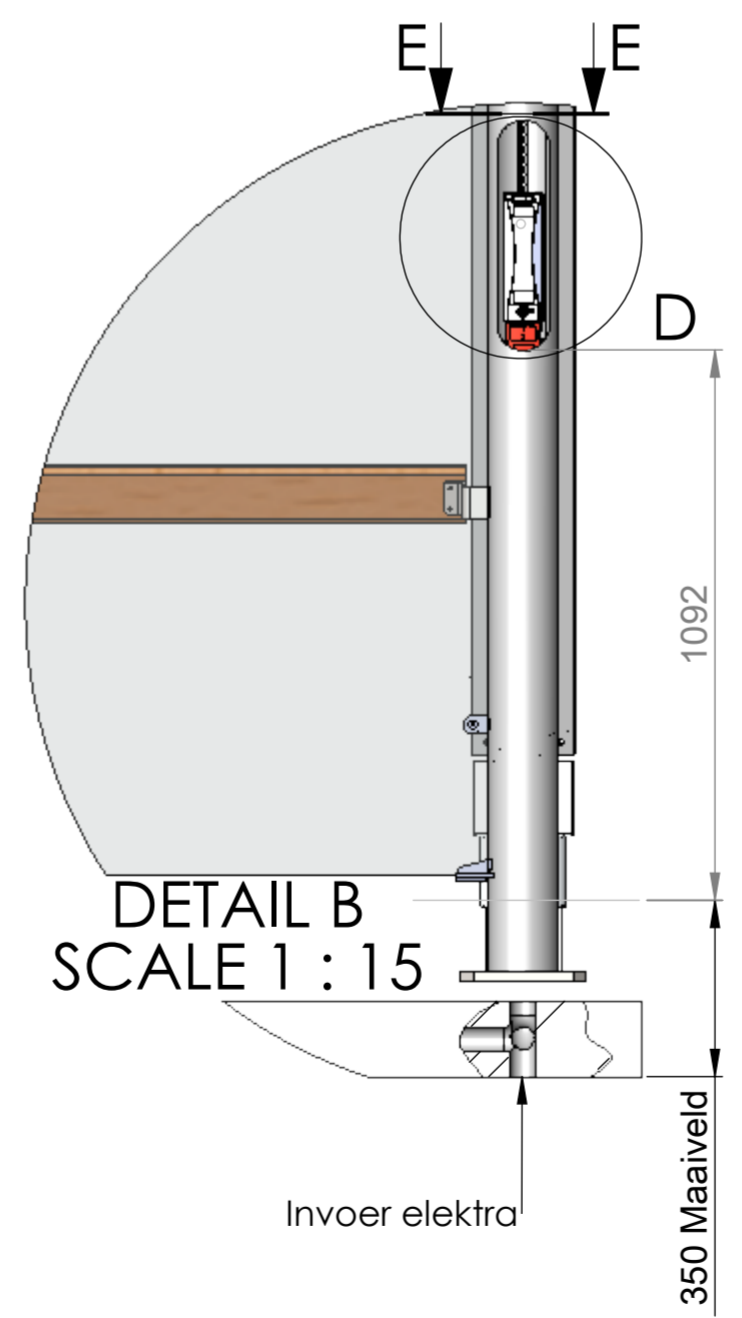
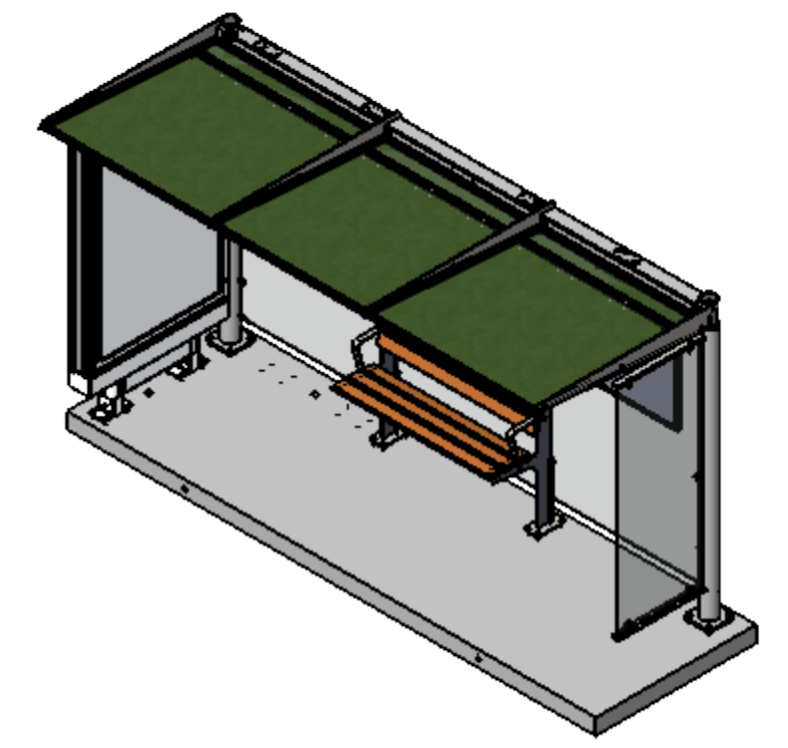

DETAIL B
SCALE 1 : 15

Invoer elektra

350 Maaiveld

Alle rechten voorbehouden, geheel of gedeeltelijke reproductie is strafbaar. Het is niet toegestaan de afbeeldingen te kopiëren of te verspreiden. De afbeeldingen zijn auteursrechtelijk beschermd.

All rights reserved, reproduction in whole or in part is prohibited without written consent of the copyright owner.

Opmerking		Description		Revision	
Surface treatment / Finishing		-VDL / Global Luxabri		1	
Material		Drawn by JvdH		Drawing number	
Third angle		Date		VDL / Global Lux	
Roughness		Released by		Weight	
Unit mm		Release date		3370366.62	
VDL		VD Leegte Metaal		Sheet 1	
Telefoon 0497-331100 Fax 0497-331101 Email info@vdlleegtemetaal.nl		Scale 1:25		Number of sheets 1	
		Format A2			